

# QUANTUM JAZZY SERIES



**OWNER'S MANUAL**

*Including Models: Quantum 1650 2SPVHD, Quantum 1650 3SPVHD,  
Jazzy 1650 2EHD, Jazzy 1650 3EHD*

**Pride**  
Mobility Products Corp.  
[www.pridemobility.com](http://www.pridemobility.com)

1-800-800-8586 (US) 1-888-570-1113 (Canada)

# SAFETY GUIDELINES

The symbols below are used throughout this owner's manual and on the power chair to identify warnings and important information. It is very important for you to read them and understand them completely.



**WARNING!** Indicates a potentially hazardous condition/situation. Failure to follow designated procedures can cause either personal injury, component damage, or malfunction. On the product, this icon is represented as a black symbol on a yellow triangle with a black border.



**MANDATORY!** These actions should be performed as specified. Failure to perform mandatory actions can cause personal injury and/or equipment damage. On the product, this icon is represented as a white symbol on a blue dot with a white border.



**PROHIBITED!** These actions are prohibited. These actions should not be performed at any time or in any circumstances. Performing a prohibited action can cause personal injury and/or equipment damage. On the product, this icon is represented as a black symbol with a red circle and red slash.

## Quick Reference Information

Authorized Provider/Specialist: \_\_\_\_\_

Address: \_\_\_\_\_

Phone Number: \_\_\_\_\_

Purchase Date: \_\_\_\_\_

***NOTE: This owner's manual is compiled from the latest specifications and product information available at the time of publication. We reserve the right to make changes as they become necessary. Any changes to our products may cause slight variations between the illustrations and explanations in this manual and the product you have purchased.***

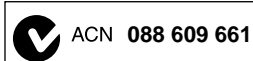

Copyright © 2006

Pride Mobility Products Corp.

INFMANU2395/Rev C/December 2006

# C O N T E N T S

I. INTRODUCTION.....	4
II. SAFETY .....	6
III. YOUR POWER CHAIR.....	16
IV. ASSEMBLY.....	21
V. COMFORT ADJUSTMENTS.....	23
VI. BATTERIES AND CHARGING .....	28
VII. CARE AND MAINTENANCE .....	32
VIII. WARRANTY.....	38

# I . I N T R O D U C T I O N

## SAFETY

WELCOME to Quantum Rehab, a division of Pride Mobility Products Corporation (Pride). The power chair you have purchased combines state-of-the-art components with **safety**, comfort, and styling in mind. We are confident that these design features will provide you with the conveniences you expect during your daily activities. Once you understand how to **safely** operate and care for your power chair, it should give you years of trouble free operation and service.

**Read and follow** all instructions, warnings, and notes in this manual before attempting to operate your power chair for the first time. In addition, your **safety** depends upon you, as well as your provider, caretaker, or healthcare professional in using good judgement.

If there is any information in this manual which you do not understand, or if you require additional assistance for setup or operation, please contact your authorized provider/specialist. **Failure to follow the instructions in this manual and those located on your power chair can lead to personal injury and/or damage to the power chair, including voiding the warranty.**

## PURCHASER'S AGREEMENT

By accepting delivery of this product, you promise that you will not change, alter, or modify this product or remove or render inoperable or unsafe any guards, shields, or other safety features of this product; fail, refuse, or neglect to install any retrofit kits from time to time provided by Pride to enhance or preserve the safe use of this product.

## SHIPPING AND DELIVERY

Before using your power chair, make sure your delivery is complete as some components may be individually packaged. If you do not receive a complete delivery, please contact your authorized provider/specialist immediately. Where damage has occurred during transport, either to the packaging or content, please contact the delivery company responsible.

## INFORMATION EXCHANGE

We want to hear your questions, comments, and suggestions about this manual. We would also like to hear about the safety and reliability of your new power chair, and about the service you received from your authorized provider/specialist.

Please notify us of any change of address, so we can keep you apprised of important information about safety, new products, and new options that can increase your ability to use and enjoy your power chair. Please feel free to contact us at the address below:

### USA:

Pride Mobility Products Corporation  
Attn.: Customer Care Department  
182 Susquehanna Avenue  
Exeter, PA 18643-2694  
customercare@pridemobility.com  
800-424-8205

### Canada:

Pride Mobility Products Company  
380 Vansickle Road Unit 350  
St. Catharines, Ontario L2R 6P7  
1-888-570-1113

***NOTE: If you ever lose or misplace your product registration card or your copy of this manual, contact us and we will be glad to send you a new one immediately.***

# I . I N T R O D U C T I O N

## PRIDE OWNERS CLUB

As an owner of a Pride product, you are encouraged to enroll in the Pride Owners Club. Complete and return your enclosed product registration card or visit Pride's web site at [www.pridemobility.com](http://www.pridemobility.com).

From our home page, select "Owners Club" to enter a page dedicated to current and potential Pride product owners. You will gain access to interviews, stories, recreation ideas, daily living tips, product and funding information, and interactive message boards. These message boards invite you to communicate with other Pride customers as well as Pride representatives who are available to assist you with any questions or concerns you may have.

# II. SAFETY

## PRODUCT SAFETY SYMBOLS

The symbols below are used on the power chair to identify warnings, mandatory actions, and prohibited actions. It is very important for you to read and understand them completely.



Corrosive chemicals contained in battery. Use only AGM or Gel-Cell batteries to reduce the risk of leakage or explosive conditions.



This product has been tested and passed at an immunity level of 20 V/m.



Read and follow the information in the owner's manual.



Maximum seating weight.



Unlocked and in freewheel mode.

Place unit on level ground and stand behind or to one side when changing from drive mode to freewheel mode or freewheel mode to drive mode.

Locked and in drive mode.

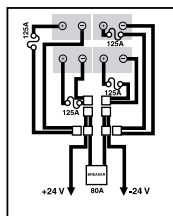

Four (4) Battery Set Configuration:

+ = Positive (Red) Terminal Post

- = Negative (Black) Terminal Post

Connect the Red wires to the Red Positive (+) Terminal Posts

Connect the Black wires to the Black Negative (-) Terminal Posts

## II. SAFETY

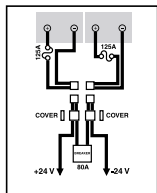

Two (2) Battery Set Configuration:

+ = Positive (Red) Terminal Post

- = Negative (Black) Terminal Post

Connect the Red wires to the Red Positive (+) Terminal Posts

Connect the Black wires to the Black Negative (-) Terminal Posts



Do not remove anti-tip wheels.



Do not use a cell phone, walkie/talkie, laptop, or other radio transmitter while operating.



Avoid exposure to rain, snow, ice, salt, or standing water whenever possible. Maintain and store in a clean and dry condition.



Removal of grounding prong can create electrical hazard. If necessary, properly install an approved 3-pronged adapter to an electrical outlet having 2-pronged plug access.

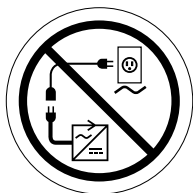

Do not connect an extension cord to the AC/DC converter or the battery charger.



Keep your hands away from the tires when driving. Be aware that loose fitting clothing can become caught in drive tires.



Disposal and recycling - Contact your authorized provider/specialist for information on proper disposal and recycling of your Pride product and its packaging.

# II. SAFETY

## GENERAL GUIDELINES



**MANDATORY!** Do not operate your new power chair for the first time without completely reading and understanding this owner's manual.

Your power chair is a state-of-the-art life-enhancement device designed to increase mobility. Pride provides an extensive variety of products to best fit the individual needs of the power chair user. Please be aware that the final selection and purchasing decision regarding the type of power chair to be used is the responsibility of the power chair user, who is capable of making such a decision, and his/her healthcare professional (i.e., medical doctor, physical therapist, etc.).

The contents of this manual are based on the expectation that a mobility device expert has properly fitted the power chair to the user and has assisted the prescribing healthcare professional and/or the authorized provider/specialist in the instruction process for the use of the product.

There are certain situations, including some medical conditions, where the power chair user will need to practice operating the power chair in the presence of a trained attendant. A trained attendant can be defined as a family member or care professional specially trained in assisting a power chair user in various daily living activities.

As you begin using your power chair during daily activities, you will probably encounter situations in which you will need some practice. Simply take your time and you will soon be in full and confident control as you maneuver through doorways, on and off of elevators, up and down ramps, and over moderate terrain.

Below are some precautions, tips, and other safety considerations that will help you become accustomed to operating your power chair safely.

### Modifications

Pride has designed and engineered your power chair to provide maximum mobility and utility. A wide range of accessories is available from your authorized provider/specialist to further customize your power chair to better suit your needs and/or preferences. However, under no circumstances should you modify, add, remove, or disable any feature, part, or function of your power chair.



**WARNING!** Do not modify your power chair in any way not authorized by Pride. Do not use accessories if they have not been tested or approved for Pride products.

### Pre-Ride Safety Check

Get to know the feel of your power chair and its capabilities. Pride recommends that you perform a safety check before each use to make sure your power chair operates smoothly and safely.

### Perform the following inspections prior to using your power chair:

- Check for proper tire inflation. Maintain but do not exceed **35 psi (2.4 bar)** in each tire if equipped with pneumatic tires.
- Check all electrical connections. Make sure they are tight and not corroded.
- Check all controller connections to the power base. Make sure they are secured properly.
- Check the brakes. See VII. "Care and Maintenance."
- Check battery charge. See VI. "Batteries and Charging."

**NOTE:** *If you discover a problem, contact your authorized provider/specialist for assistance.*



# II. SAFETY

## Weight Limitations

Your power chair is rated for a maximum weight capacity. Please refer to the specifications table for this limit.



WARNING! Stay within the specified weight capacity of your power chair. Exceeding the weight capacity voids your warranty. Pride will not be held responsible for injuries and/or property damage resulting from failure to observe weight limitations.

WARNING! Do not carry passengers on your power chair. Carrying passengers on your power chair may affect the center of gravity, resulting in a tip or a fall.

## Tire Inflation

If your power chair is equipped with pneumatic tires, you should check or have the air pressure checked regularly. Proper inflation pressures will prolong the life of your tires and help ensure the smooth operation of your power chair.



WARNING! It is important that 35 psi (2.4 bar) tire pressure be maintained in pneumatic tires at all times. Do not underinflate or overinflate your tires. Low pressure may result in loss of control, and overinflated tires may burst. Failure to maintain 35 psi (2.4 bar) tire pressure in pneumatic tires at all times may result in tire and/or wheel failure.

WARNING! Inflate your power chair drive tires from a regulated air source with an available pressure gauge. Inflating your tires from an unregulated air source could overinflate them, resulting in a burst tire.

## Incline Information

More and more buildings have ramps with specified degrees of inclination, designed for easy and safe access. Some ramps may have turning switchbacks (180-degree turns) that require you to have good cornering skills on your power chair.

- Proceed with extreme caution as you approach the downgrade of a ramp or other incline.
- Take wide swings with your power chair's front wheels around any tight corners. If you do that, the power chair's rear wheels will follow a wide arc, not cut the corner short, and not bump into or get hung up on any railing corners.
- When driving down a ramp, keep the power chair's speed adjustment set to the slowest speed setting to ensure a safely controlled descent.
- Avoid sudden stops and starts.

When climbing an incline, try to keep your power chair moving. If you must stop, start up again slowly and then accelerate cautiously. When driving down an incline, set your power chair to the slowest speed setting and drive in the forward direction only. If your power chair starts to move down the incline faster than you anticipated or desired, allow it to come to a complete stop by releasing the joystick, then push the joystick forward slightly to ensure a safely controlled descent.

WARNING! When climbing an incline, do not zigzag or drive at an angle up the face of the incline. Drive your power chair straight up the incline. This greatly reduces the possibility of a tip or a fall. Always exercise extreme caution when negotiating an incline.

WARNING! You should not travel up or down a potentially hazardous incline (i.e., areas covered with snow, ice, cut grass, or wet leaves).



WARNING! When on any sort of an incline or decline, never place the power chair in freewheel mode while seated on it or standing next to it.

WARNING! Never travel down an incline backward. Doing so may cause the power chair tip.

WARNING! If your power chair is equipped with a reclining seatback, do not attempt to negotiate inclines with the seat in a reclined position. Do not attempt to negotiate obstacles with the seat in a reclined position unless an attendant is present to help stabilize the chair. Failure to heed may result in the power chair tipping over.

## II. SAFETY



WARNING! Even though your power chair is capable of climbing slopes greater than those illustrated in figure 1, do not, under any circumstances, exceed the incline guidelines or any other specifications presented in this manual. Doing so could cause instability in your power chair.

In compliance with the Americans with Disabilities Act of 1990, all handicap public access ramps are required to have a maximum slope of 5° (8.7%). Therefore, Pride recommends that the maximum slope of an incline you attempt to safely ascend or descend on your power chair does not exceed 5° (8.7%). See figure 1.



WARNING! Any attempt to climb or descend a slope steeper than 5° (8.7%) may put your power chair in an unstable position and cause it to tip.

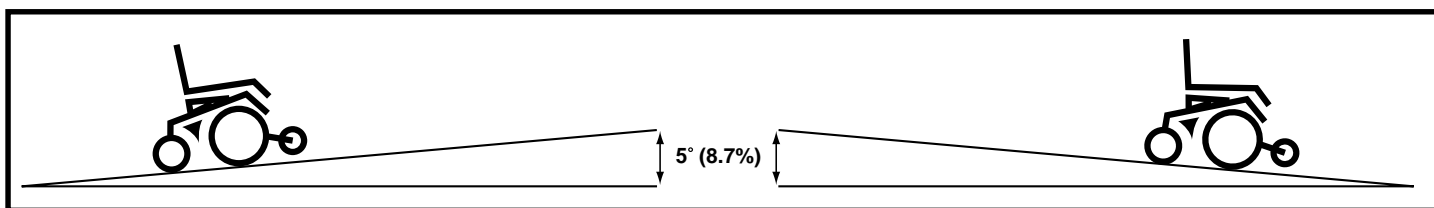

Figure 1. Maximum Safe Slope (Ascending and Descending)

### Freewheel Mode

Your power chair is equipped with two manual freewheel levers to allow for manual maneuverability by a trained attendant. For more information about how to place your power chair into and out of freewheel mode, see III. “Your Power Chair.”

WARNING! Do not use your power chair in freewheel mode without an attendant present.



WARNING! Do not attempt to personally place your power chair in freewheel mode while seated on it. Ask an attendant for assistance if necessary.

WARNING! Do not place your power chair in freewheel mode while on an incline. This could cause the chair to roll uncontrollably on its own.

### Braking Information

Your power chair is equipped with two powerful brake systems:

- Regenerative — uses electricity to rapidly slow the vehicle when the joystick returns to the center/stop position.
- Disc Park Brake — activates mechanically after regenerative braking slows the vehicle to near stop, or when power is removed from the system for any reason.

### Cornering Information

While your power chair is equipped with rear caster wheels and front anti-tip wheels, excessively high cornering speeds can still create the possibility of tipping. Factors which affect the possibility of tipping include, but are not limited to: cornering speed, steering angle (how sharply you are turning), uneven road surfaces, inclined road surfaces, riding from an area of low traction to an area of high traction (such as passing from a grassy area to a paved area – especially at high speed while turning), and abrupt directional changes. High cornering speeds are not recommended. If you feel that you may tip over in a corner, reduce your speed and steering angle (i.e., lessen the sharpness of the turn) to prevent your power chair from tipping.



WARNING! When cornering sharply, reduce your speed and maintain a stable center of gravity. This greatly reduces the possibility of a tip or fall.

# II. SAFETY

## Public Streets and Roadways



WARNING! You should not operate your power chair on public streets and roadways. Be aware that it may be difficult for traffic to see you when you are seated on your power chair. Obey all local pedestrian traffic rules. Wait until your path is clear of traffic, and then proceed with extreme caution.

## Outdoor Driving Surfaces

Your power chair is designed to provide optimum stability under normal driving conditions—dry, level surfaces composed of concrete, blacktop, or asphalt. However, Pride recognizes that there will be times when you will encounter other surface types. For this reason, your power chair is designed to perform admirably on packed soil, grass, and gravel. Feel free to use your power chair safely on lawns and in park areas.

- Reduce your power chair's speed when driving on uneven terrain and/or soft surfaces.
- Avoid tall grass that can entangle the running gear.
- Avoid loosely packed gravel and sand.
- If you feel unsure about a driving surface, avoid that surface.

## Inclement Weather Precautions

Exposure of your power chair to inclement weather conditions should be avoided whenever possible. If suddenly caught up in rain, snow, severe cold or heat while operating your power chair, proceed to shelter at the earliest opportunity. Thoroughly dry your power chair before storing, charging, or operating your power chair.

WARNING! Operating in rain, snow, salt, mist/spray conditions, and on icy/slippery surfaces can have an adverse affect on the electrical system. Maintain and store your power chair in a dry and clean condition.



WARNING! Prolonged exposure to hot or cold conditions may affect the temperature of upholstered and non-upholstered items on the power chair, possibly resulting in skin irritation. Exercise caution when using your power chair in extremely hot or cold conditions or when exposing your power chair to direct sunlight for prolonged periods of time.

## Stationary Obstacles (Steps, Curbs, etc.)

Proceed with extreme caution when driving near raised surfaces, unprotected ledges and/or drop-offs (curbs, porches, stairs, etc.). Be sure your power chair is traveling perpendicular to any curb you may be required to navigate. See figure 2.

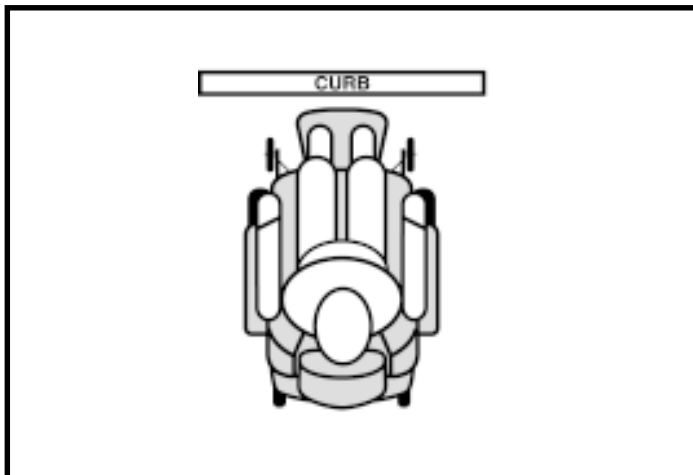

Figure 2. Correct Curb Approach



Figure 3. Incorrect Curb Approach

# II. SAFETY



WARNING! Do not attempt to have your power chair climb or descend an obstacle that is higher than 2 in. (5 cm) unless you have the assistance of an attendant.

WARNING! Do not attempt to have your power chair proceed backward down any step, curb, or other obstacle. This may cause the power chair to tip.

## Stairs and Escalators

Power chairs are not designed to travel up or down stairs or escalators. Always use an elevator.



WARNING! Never use your power chair to negotiate steps or escalators.

## Doors

- Determine if the door opens toward or away from you.
- Drive your power chair gently and slowly forward to push the door open. Or drive your power chair gently and slowly backward to pull the door open.

## Elevators

Modern elevators have a door edge safety mechanism that, when pushed, reopens the elevator door(s).

- If you are in the doorway of an elevator when the door(s) begin to close, push on the rubber door edge or allow the rubber door edge to contact the power chair and the door will reopen.
- Use care that pocketbooks, packages, or power chair accessories do not become caught in elevator doors.

## Lift/Elevation Products

If you will be traveling with your power chair, you may find it necessary to use a lift/elevation product to aid in transportation. Pride recommends that you closely review the instructions, specifications, and safety information set forth by the manufacturer of the lift/elevation product before using that product.



WARNING! Never sit on your power chair when it is being used in connection with any type of lift/elevation product. Your power chair was not designed with such use in mind and any damage or injury incurred from such use is not the responsibility of Pride.

## Motor Vehicle Transport

Pride recommends that you do not remain seated in your power chair while traveling in a motor vehicle. The power chair should be stowed in the trunk of a car or in the back of a truck or van with batteries removed and properly secured.

WARNING! Do not sit on your power chair while it is in a moving vehicle.



WARNING! Always be sure your power chair and its batteries are properly secured when it is being transported. Batteries should be secured in an upright position and protective caps should be installed on the battery terminals. Batteries should not be transported with any flammable or combustible items.

## Positioning Belts

Your authorized provider/specialist, therapist(s), and other healthcare professionals are responsible for determining your requirement for a positioning belt in order to operate your power chair safely.



WARNING! If you require a positioning belt to safely operate your power chair, make sure it is fastened securely in order to reduce the possibility of a fall from the power chair.

WARNING! The positioning belt is not designed for use as a seat belt in a motor vehicle. Nor is your power chair suitable for use as a seat in any vehicle. Anyone traveling in a vehicle should be properly belted into seats approved by the vehicle manufacturer.

# II. SAFETY

## Batteries

In addition to following the warnings below, be sure to comply with all other battery handling information. For more information about your power chair's batteries, see VI. "Batteries and Charging."

WARNING! Power chair batteries are heavy. See specifications table. If you are unable to lift that much weight, be sure to get help. Use proper lifting techniques and avoid lifting beyond your capacity.

WARNING! Battery posts, terminals, and related accessories contain lead and lead compounds. Wash hands after handling.



WARNING! Always protect the batteries from freezing and never charge a frozen battery. Charging a frozen battery may result in damage to the battery.

WARNING! Connect your battery harnesses in the proper manner. RED (+) cables must be connected to positive (+) battery terminals/posts. BLACK (-) cables must be connected to negative (-) battery terminals/posts. Protective caps should be installed over all battery terminals. REPLACE cables immediately if damaged.

## Removable Parts



WARNING! Do not attempt to lift or move a power chair by any of its removable parts, including the armrests, seat, foot riggings, controller, and shrouds.

## Preventing Unintended Movement



WARNING! If you anticipate being seated in a stationary position for an extended period of time, turn off the power. This will prevent unexpected motion from inadvertent joystick contact. This will also eliminate the possibility of unintended chair movement from electromagnetic (EM) sources.

## Reaching and Bending

Never reach, lean, or bend while driving your power chair. If it is absolutely necessary to reach, lean, or bend while seated on your power chair, it is important to maintain a stable center of gravity and keep the power chair from tipping. Pride recommends that the power chair user determine his/her personal limitations and practice bending and reaching in the presence of a qualified healthcare professional.



WARNING! Do not bend, lean, or reach for objects if you have to pick them up from the floor by reaching down between your knees or if you have to reach over the back of the seat. Movements such as these may change your center of gravity and the weight distribution of the power chair, possibly causing your power chair to tip.

WARNING! Keep your hands away from the tires when driving. Be aware that loose fitting clothing can become caught in drive tires.

# II. SAFETY

## Transfers

Transferring onto and off of your power chair requires a good sense of balance. Always have an attendant or health-care professional present while learning to properly transfer yourself.

To eliminate the possibility of injury, Pride recommends that you or a trained attendant perform the following tasks before attempting a transfer:

- Turn off the power to the controller.
- Ensure your power chair is not in freewheel mode. See III. “Your Power Chair.”
- Turn the caster wheels toward the transfer destination to improve power chair stability during transfer.
- Make sure both armrests are flipped up or removed from your power chair.
- Flip up the foot platform or move the leg rests aside; this will help to keep your feet from getting caught on the foot rigging during the transfer.
- Reduce the distance between your power chair and the object you are transferring onto.

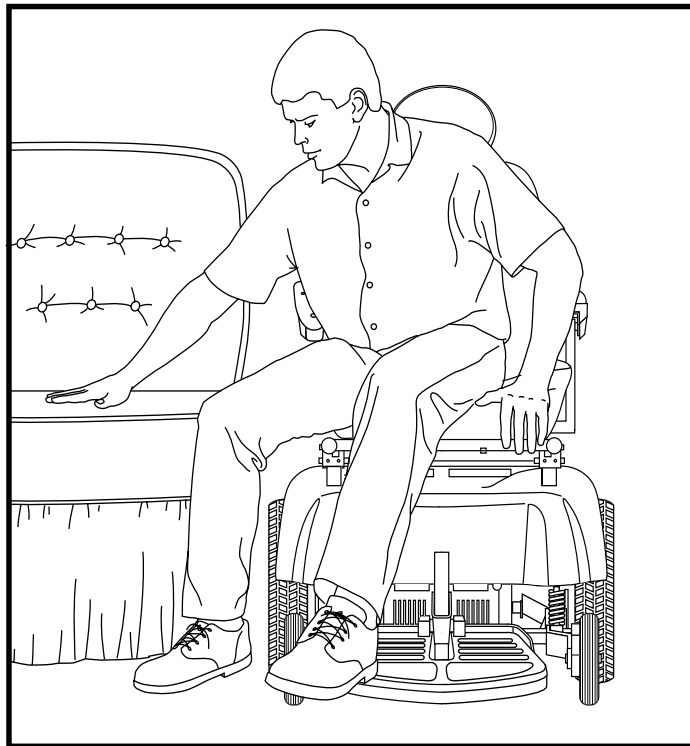

Figure 4. Ideal Transfer Position

WARNING! Before transferring, position yourself as far back as possible in the power chair seat to prevent the power chair from tipping forward during transfer.



WARNING! Avoid putting all of your weight on the power chair armrests and do not use the armrests for weight bearing purposes, such as transfers. Such use may cause the power chair to tip, resulting in a fall from the power chair.

WARNING! Avoid putting all of your weight on the foot riggings. Such use may cause the power chair to tip.

## Prescription Drugs/Physical Limitations

Users must exercise care and common sense when operating a power chair. This includes awareness of safety issues when taking prescribed or over-the-counter drugs or when the user has specific physical limitations.



WARNING! Consult your physician if you are taking prescribed or over-the-counter medication or if you have certain physical limitations. Some medications and limitations may impair your ability to operate your power chair in a safe manner.

## Alcohol/Smoking

The power chair user must exercise care and common sense when operating his/her power chair. This includes awareness of safety issues while under the influence of alcohol or while smoking.



WARNING! Do not operate your power chair while you are under the influence of alcohol, as this may impair your ability to operate your power chair in a safe manner.

## II. SAFETY



WARNING! Although the power chair seat has passed the necessary testing requirements for cigarette smoke, Pride recommends that you adhere to the following safety guidelines:

- Do not leave lit cigarettes unattended.
- Keep ashtrays a safe distance from the seat cushions.
- Always make sure cigarettes are completely extinguished before disposal.

### Electromagnetic and Radio Frequency Interference (EMI/RFI)



WARNING! Laboratory tests have shown that electromagnetic and radio frequency waves can have an adverse affect on the performance of electrically-powered mobility vehicles.

Electromagnetic and Radio Frequency Interference can come from sources such as cellular phones, mobile two-way radios (such as walkie-talkies), radio stations, TV stations, amateur radio (HAM) transmitters, wireless computer links, microwave signals, paging transmitters, and medium-range mobile transceivers used by emergency vehicles. In some cases, these waves can cause unintended movement or damage to the control system. Every electrically-powered mobility vehicle has an immunity (or resistance) to EMI. The higher the immunity level, the greater the protection against EMI. This product has been tested and has passed at an immunity level of 20 V/m.

WARNING! Be aware that cell phones, two-way radios, laptops, and other types of radio transmitters may cause unintended movement of your electrically-powered mobility vehicle due to EMI. Exercise caution when using any of these items while operating your mobility vehicle and avoid coming into close proximity of radio and TV stations.



WARNING! The addition of accessories or components to the electrically-powered mobility vehicle can increase the susceptibility of the vehicle to EMI. Do not modify your power chair in any way not authorized by Pride.

WARNING! The electrically-powered mobility vehicle itself can disturb the performance of other electrical devices located nearby, such as alarm systems.

***NOTE: For further information on EMI/RFI, go to the Resource Center on [www.pridemobility.com](http://www.pridemobility.com). If unintended motion or brake release occurs, turn your power chair off as soon as it is safe to do so. Call Pride at 800-424-8205 to report the incident.***

# III. YOUR POWER CHAIR

## THE QUANTUM JAZZY 1650 SERIES POWER CHAIR

Your power chair has two main assemblies: the seat and the power base. See figures 5 and 6. Typically, the seat assembly includes the armrests, seatback, and seat base. The power base assembly includes two motor/brake assemblies, two drive wheels, two anti-tip wheels, two caster wheels, two batteries, and the electrical components.



Figure 5. The Quantum Jazzy 1650 Series Power Chair



# III. YOUR POWER CHAIR

## QUANTUM JAZZY 1650 SPECIFICATIONS

Suspension:	Limited
Drive Wheels:	16 in. (40.64 cm), pneumatic or solid, center-mounted
Caster Wheels:	9 in. (22.86 cm), pneumatic, rear articulating
Anti-tip Wheels:	8 in. (20.32 cm), solid, front-mounted
Maximum Speed: <sup>1</sup>	Up to 5 mph (8.04 km/h)
Range: <sup>1</sup>	Variable up to 10 miles (16 km)
Brakes:	"Intelligent Braking" electronic regenerative, disc park brake
Ground Clearance: <sup>2</sup>	4.25 in. (10.8 cm)
Turning Radius: <sup>2</sup>	26.25 in. (66.675 cm)
Overall Size: <sup>2</sup>	Length: 47 in. (119.38 cm) without foot riggings Width: 30.375 in. (77.15 cm)
Drivetrain:	Two motor, mid-wheel
Batteries: <sup>3</sup>	Two 12-volt, deep-cycle Group 24 Four 12-volt, deep-cycle NF-22 batteries (extended range package)
Battery Charger:	8-amp, off-board
Weight Capacity:	Quantum 1650 Series: 500 lbs. (226.79 kg) Jazzy 1650 Series: 650 lbs. (294.84 kg)
Component Weights:	Base: 176 lbs. (79.83 kg) Batteries: 53.5 lbs. (24.26 kg) each (Group 24), 38 lbs. (17.23 kg) each (NF-22)

<sup>1</sup> Varies with base model, user weight, terrain type, battery amp hour rating (AH), battery charge, battery condition, motors, controller type, tire type, and tire condition.

<sup>2</sup> Due to manufacturing tolerances and continued product improvement, this specification can be subject to variance of (+ or -) 3%.

<sup>3</sup> AGM or Gel-Cell recommended.

**NOTE: All specifications subject to change without notice.**

# III. YOUR POWER CHAIR

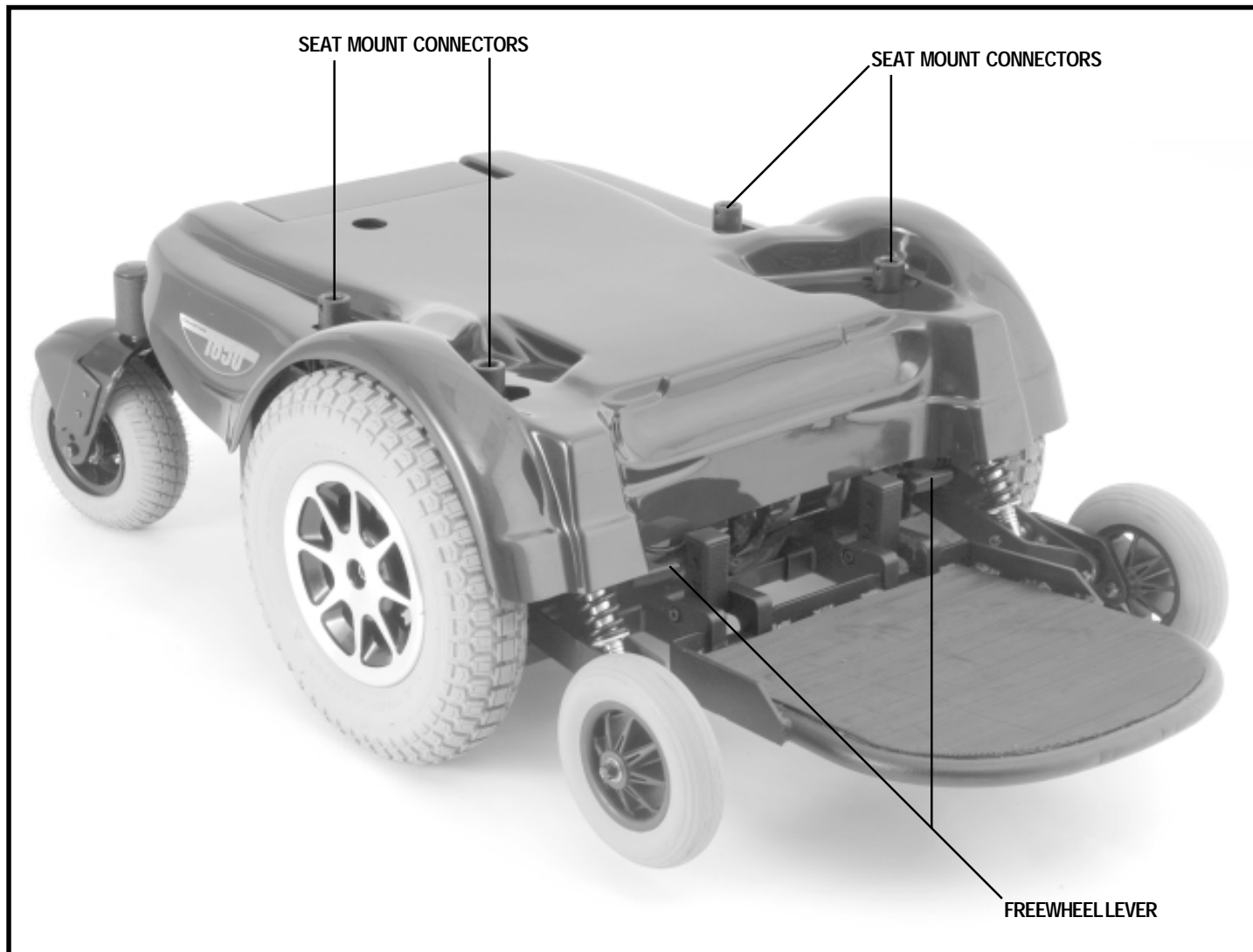

Figure 6. The Quantum Jazzy 1650 Series Power Base

## Electrical Components

The electrical components are located on the power base. See figure 7.

**Thermal Fuse:** The thermal fuse is located on the front of the power base. If the batteries and the motors are heavily strained (e.g., from excessive loads), the thermal fuse will reduce the amount of current going to the electronic controller by 60%. The current will automatically return to 100% when the fuse cools to within its normal operating temperature range.

**Power Module:** The power module supplies battery power to the motors. It is connected to the Remote Plus through a communications cable.

**Battery Connectors:** The battery connectors provide a connection between the battery wiring harnesses and the power module. The standard battery package has two battery connectors. The extended range package has four battery connectors.

# III. YOUR POWER CHAIR

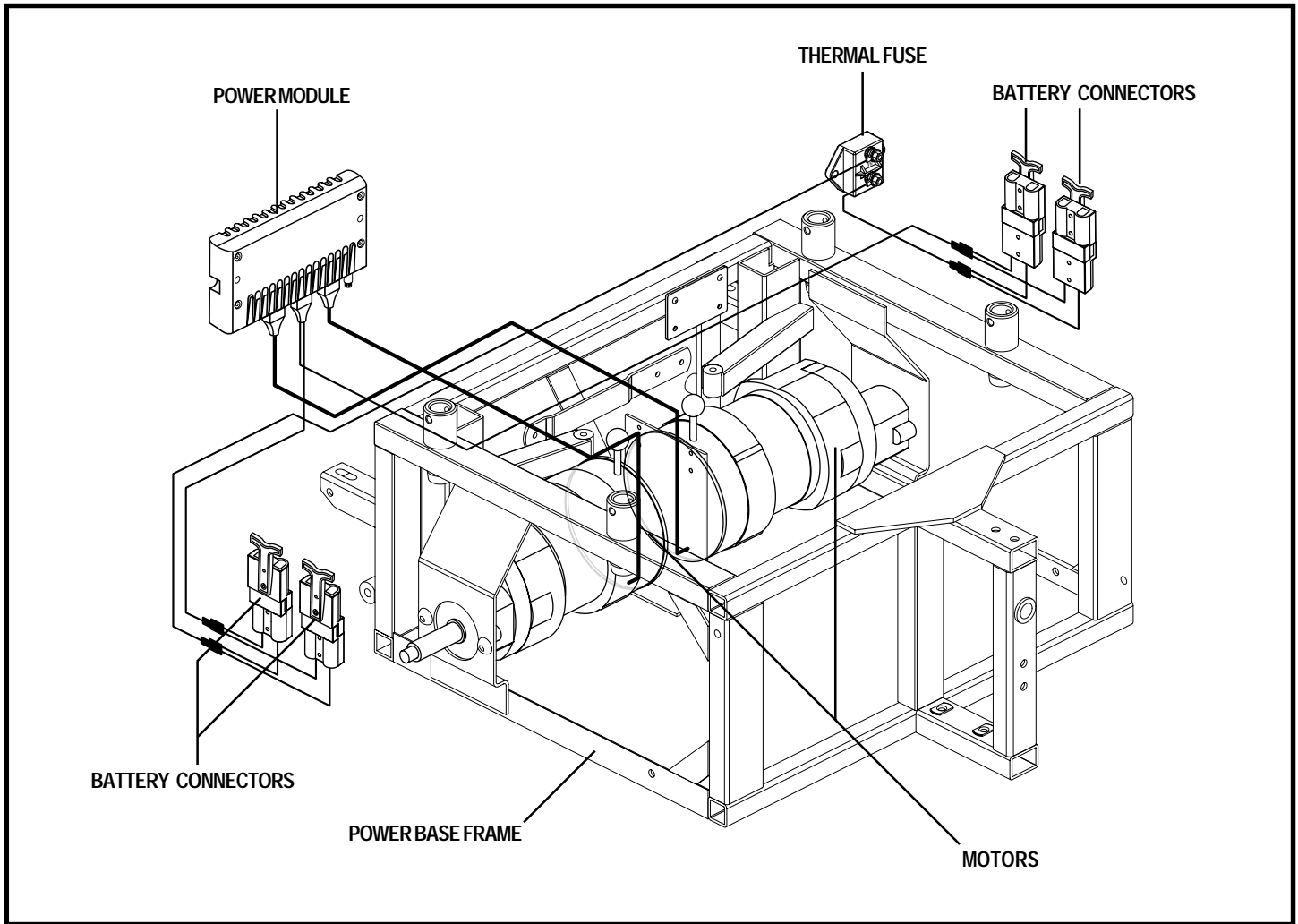

Figure 7. Quantum Jazzy 1650 Series Electrical Components (4-battery configuration shown)

# III. YOUR POWER CHAIR

## Manual Freewheel Levers

Your power chair has a manual freewheel lever located on each motor. Manual freewheel levers enable you to disengage the drive motors from the gearboxes and maneuver the chair manually.



WARNING! Do not use the power chair while the drive motors are disengaged! Do not disengage the drive motors when the power chair is on an incline, as the unit could roll on its own! Only engage the freewheel mode when on a level surface.

WARNING! It is important to remember that when your power chair is in freewheel mode, the braking system is disengaged.

**NOTE:** You must turn off the power before disengaging the drive motors, otherwise you may get an error code (nine flashing lights) on the controller. To clear this code, turn off the controller and place the power chair in drive mode. Then turn on the controller. The error message should be cleared. If it fails to clear, contact your authorized provider/specialist.

### To engage or disengage the drive motors:

1. Locate the levers on the front of the power base. See figure 8.
2. Push the two levers inward to engage the drive motors (drive mode).
3. Pull the two levers outward to disengage the drive motors (freewheel mode).

If a lever is difficult to move in either direction, slightly rock the power chair back and forth. The lever should then move to the desired position.



WARNING! Do not use the freewheel lever handles as tie-down points to secure this product.

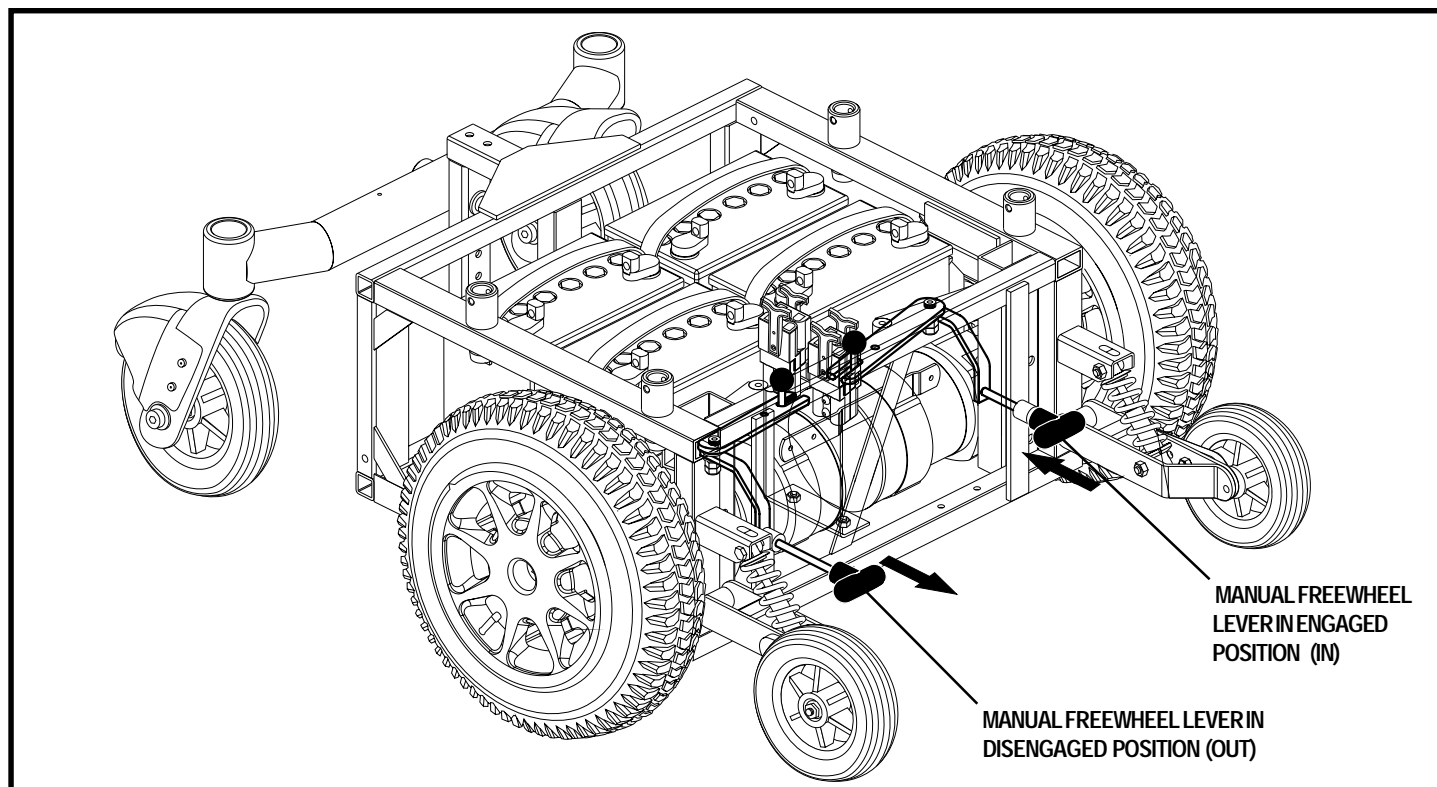

Figure 8. Manual Freewheel Levers

# IV. ASSEMBLY

## INITIAL ASSEMBLY

Your power chair may require some assembly either before initial use or after transportation. It may also require disassembly to make some comfort adjustments.

**NOTE:** Any nylon insert lock nut removed during the disassembly or adjustment of the power chair must be replaced with a new nut. Nylon insert lock nuts should not be reused as it may cause damage to the nylon insert, resulting in a less secure fit. Replacement nylon insert lock nuts are available at local hardware stores or through your authorized provider/specialist.

## Seat Installation

The power chair seat is attached to the power base by four seat pins. Each pin is inserted into a receiver on the power base frame. The seat pins have holes that enable you to adjust the seat height. Ball detent pins are inserted through the receiver and through the seat pins to secure the seat.



**WARNING!** Do not pick up the seat frame by the armrests. They are free to pivot, and you may lose control of the seat if they do so.

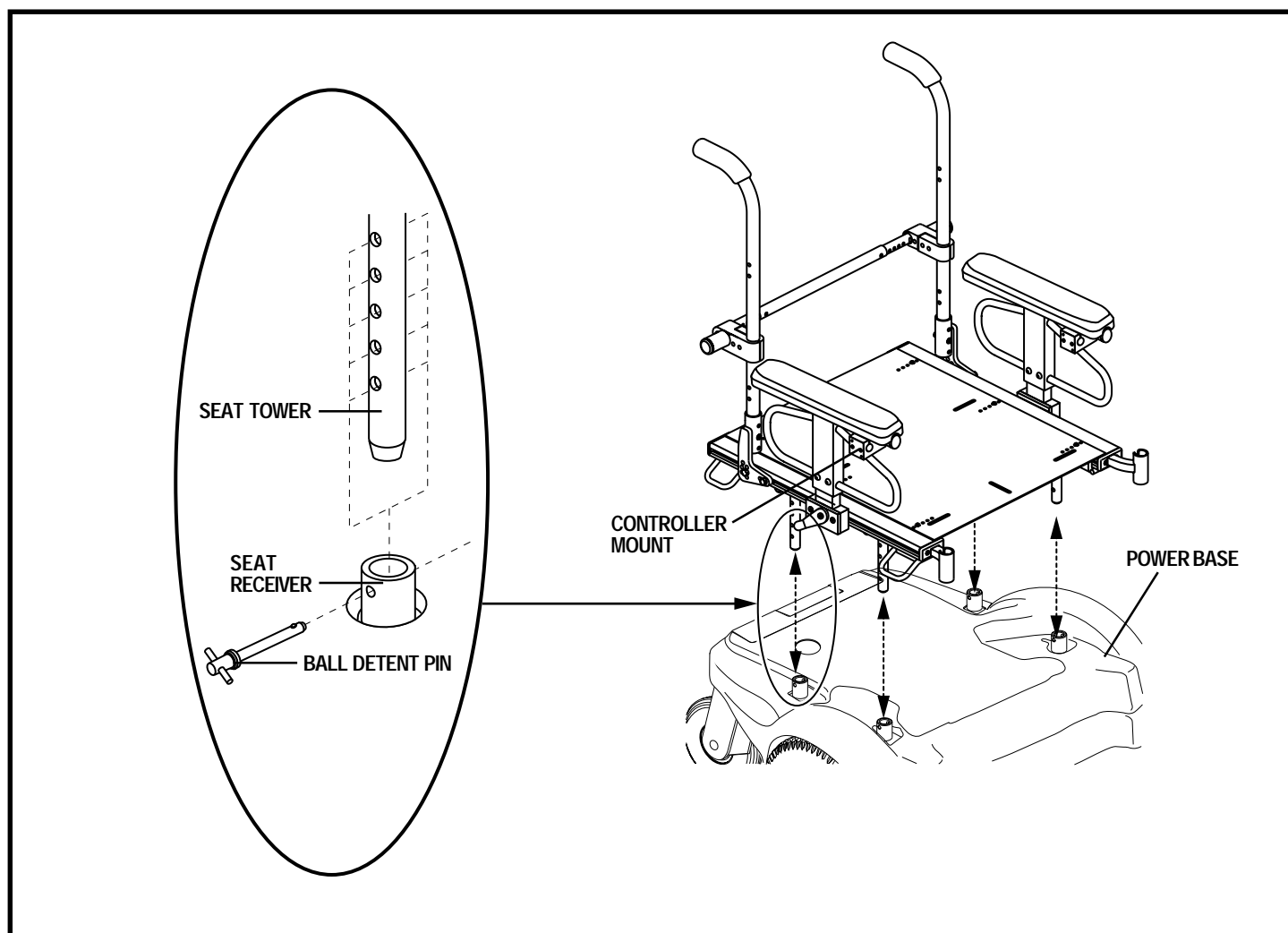

Figure 9. Seat Installation/Removal

## I V . A S S E M B L Y

### **To install the seat:**

1. Lift the seat over the power base.
2. Align each seat pin with the corresponding receiver. See figure 9.
3. Gently allow the seat to slide into each receiver until the seat is at the desired height.
4. Insert the ball detent pins into each receiver.
5. Install the armrests (if necessary). See figure 10.
6. Loosen the setscrews on the controller mount. See figure 13.
7. Slide the controller into the armrest.
8. Tighten the setscrews to secure the controller.
9. Use a wire tie to secure the controller cable to the armrest.
10. Plug the controller cable into the connector on the power base. See figure 6.

# V. COMFORT ADJUSTMENTS

## COMFORT ADJUSTMENTS

After becoming familiar with your power chair's operation, you may find the need to make some adjustments to increase your comfort, such as seat height and angle, foot platform height and angle, and controller position.

**NOTE:** *If your power chair is equipped with a Synergy Seating System, refer to the seat adjustment information contained in separate manuals. If your power chair is equipped with a contoured seating system, refer to the following information.*

WARNING! If your power chair was configured by your authorized provider/specialist, please consult your healthcare professional before changing the seat position or making any other adjustment. Some adjustments may degrade your power chair's performance and safety by changing its center of gravity.



WARNING! Some power chair components are heavy. You may need assistance to lift or carry them. Please refer to the specifications table for specific component weights before you disassemble the power chair.

WARNING! Remove the occupant from the power chair before making any adjustments.

### **You may need the following to make comfort adjustments:**

- metric/standard socket set and ratchet
- adjustable wrench

### **Seat Height and Seat Angle Adjustment**

The seat is attached to the power base by four seat pins. You can change the seat height to one of four positions by raising the front and rear seat pins. If you raise or lower only one set of seat pins (front or rear), you can also change the seat base angle (dump).

#### **To change the seat height or seat angle:**

1. Turn off the power to the controller.
2. Make sure the power chair is in drive mode. See III. "Your Power Chair."
3. Remove the ball detent pins from the seat receivers. See figure 9.
4. Move the seat up or down to the desired height.

**NOTE:** *Change the seat dump by raising or lowering only one set of pins (front or back).*

5. Reinstall the ball detent pins.

# V. COMFORT ADJUSTMENTS

## Heavy Duty Drop-in Armrests

The heavy duty drop-in armrests are attached to the chair with an armrest locking mechanism that is fastened to the side rails of the seat. These armrests can be removed for easy transfer onto and off of the power chair. Both the position and the overall height of the armrests can be adjusted.

### To remove the armrest assembly:

1. Rotate the armrest lock lever rearward. See figure 10.
2. Lift up the armrest assembly.

### To install the armrest assembly:

1. Place the armrest assembly into the armrest lock. See figure 10.
2. Rotate the armrest lock lever forward.

## Armrest Position Adjustment

The position of the armrests along the side rails can be adjusted forward or rearward.

### To adjust the armrest position:

1. Remove the armrest from the armrest lock.
2. Loosen the hardware that fasten the armrest lock to the seat base side rail. See figure 11.
3. Slide the armrest lock forward or rearward along the seat base side rail.
4. Tighten the armrest lock hardware.
5. Install the armrest in the armrest lock. See figure 11.
6. If necessary, repeat for the other armrest.

## Armrest Height Adjustment

The height of the armrest can be adjusted by sliding the armrest up or down the detent bar.

### To adjust the armrest height:

1. Rotate the armrest lock lever rearward and remove the armrest from the armrest lock. See figure 12.
2. Remove the hardware from the side of the armrest.
3. Slide the armrest up or down the detent bar to the desired height.
4. Reinstall the hardware to the side of the armrest.
5. Install the armrest in the armrest lock and rotate the lock lever forward.
6. If necessary, repeat for the other armrest.

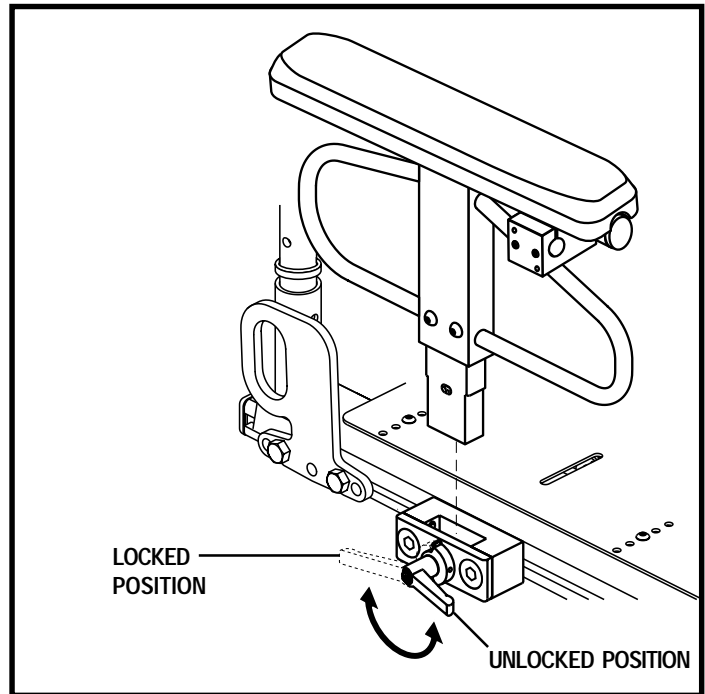

Figure 10. Armrest Removal

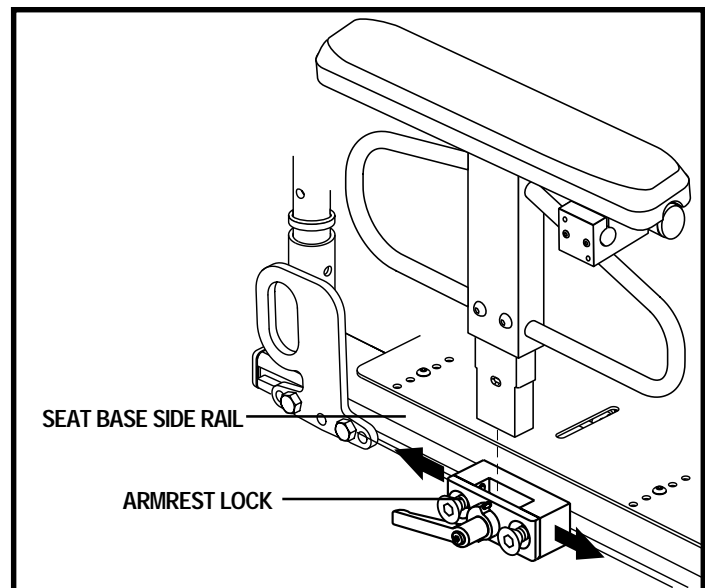

Figure 11. Armrest Position Adjustment



# V. COMFORT ADJUSTMENTS

## Controller Position

You can move the controller in toward or out away from the armrest, or change the position of the controller for either left-hand or right-hand use. See figure 13.



**WARNING!** Do not place the controller cable so that it can be pinched in the seat frame or the power base frame.

### To change the controller position:

1. Turn off the power to the controller.
2. Unplug the controller cable from the power base.
3. Remove any wire ties securing the controller cable to the armrest.
4. Loosen the mounting screws in the controller mounting block. See figure 13.
5. Slide the controller mounting block off of the armrest.
6. Reinstall the controller mounting block onto the other armrest.
7. Tighten the mounting screws.
8. Secure the controller cable to the armrest with wire ties.
9. Plug the controller cable back into the power base.

## Foot Platform Height Adjustment

The foot platform height is easily adjusted to several different heights.

### To raise or lower the foot platform:

1. Remove the hardware from the foot platform bracket. See figure 14.
2. Raise or lower the foot platform to the desired height.
3. Reinstall the hardware into the foot platform bracket and tighten.

## Foot Platform Angle Adjustment

You can adjust the angle of the foot platform with a hex key. See figure 14.

### To adjust the foot platform angle:

1. Flip up the foot platform and locate the setscrews.
2. Turn the setscrews counterclockwise to lower the front of the foot platform.
3. Turn the setscrews clockwise to raise the front of the foot platform.

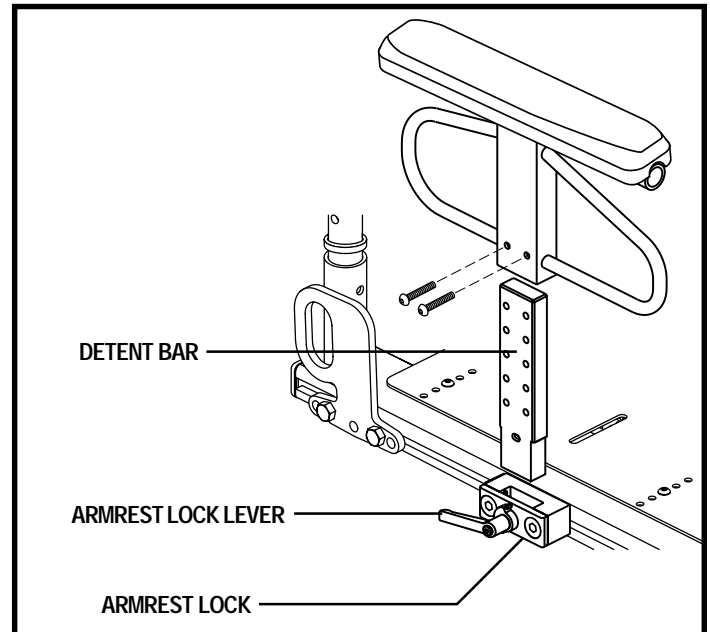

Figure 12. Armrest Height Adjustment

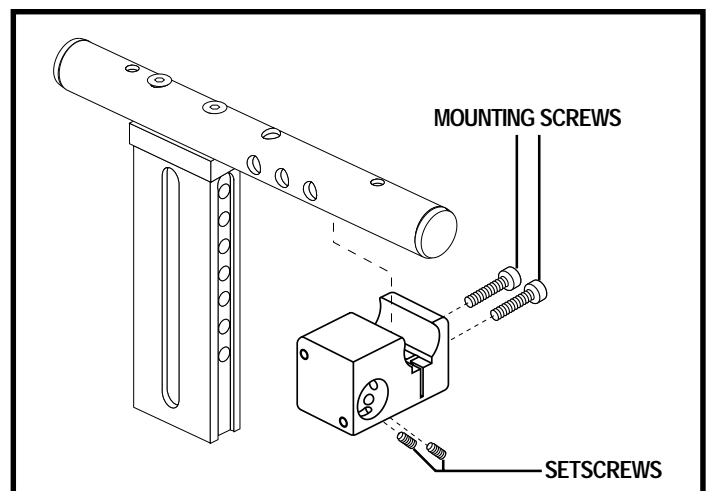

Figure 13. Controller Mounting Block

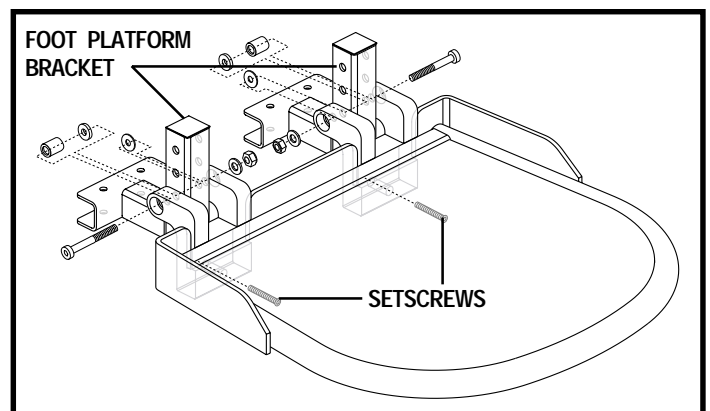

Figure 14. Foot Platform Adjustment

# V. COMFORT ADJUSTMENTS

## Heavy Duty Drop-in Leg Rests

You can adjust the forward/back position, as well as the length of the heavy duty drop-in leg rests.

### To adjust the forward/back position:

1. Remove the adjustment bolt from the side rail. See figure 15.
2. Move the leg rest hanger in or out to the desired position.
3. Align the adjustment holes in the leg rest hanger with those in the side rail.
4. Reinstall the adjustment bolt to secure the leg rest hanger.

### To adjust the leg rest length:

1. Remove the adjustment screws from the leg rest extension. See figure 15.
2. Slide the leg rest up or down to the desired length.
3. Align the adjustment holes in the leg rest extension and reinstall the adjustment screws.

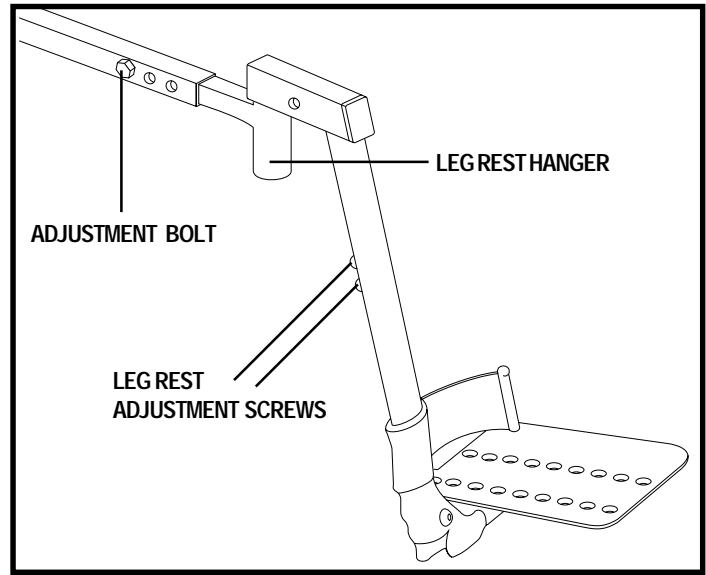

Figure 15. Heavy Duty Drop-In Leg Rests

## Anti-Tip Wheels

The anti-tip wheels are designed to give your power chair increased stability on rough surfaces. The anti-tip wheels are preset at the factory for smooth surfaces or indoor use only. If you plan on using your power chair on rough surfaces, it may be necessary to adjust the anti-tip wheels to better suit your needs. The anti-tip wheels may need adjustment if the following occurs:

- When coming to a stop, your power chair tips forward excessively.
- The anti-tip wheels constantly rub the ground.

WARNING! Consult your authorized provider/specialist before attempting to change the anti-tip wheel height! Changing the anti-tip wheel height affects handling under acceleration!



WARNING! The higher you raise the anti-tip wheels, the more you increase your power chair's tendency to tilt forward while decelerating. You can compensate for this by having your authorized provider/specialist make a small adjustment to the pre-programmed deceleration setting in the controller or by moving the seat assembly farther to the back of your power chair.



PROHIBITED! Do not remove the anti-tip wheels.

**NOTE: Each drive tire must be inflated to 35 psi (2.4 bar) if equipped with pneumatic tires and the user must also be seated in the power chair in order to properly adjust the anti-tip wheels.**

# V. COMFORT ADJUSTMENTS

## To adjust the anti-tip wheels:

1. Place a 1/2-in. wrench on the inner locknut of the anti-tip bracket located in front of the shock strut. See figure 16.
2. Turn the locknut counterclockwise to loosen.
3. Place the 1/2-in. wrench on the adjustable cam located on the other side of the locknut. To adjust the anti-tip upward, turn the cam counterclockwise. To adjust the anti-tip downward, turn the cam clockwise.
4. Raise or lower the other anti-tip wheel so that it is at the same height.
5. Tighten the locknut.

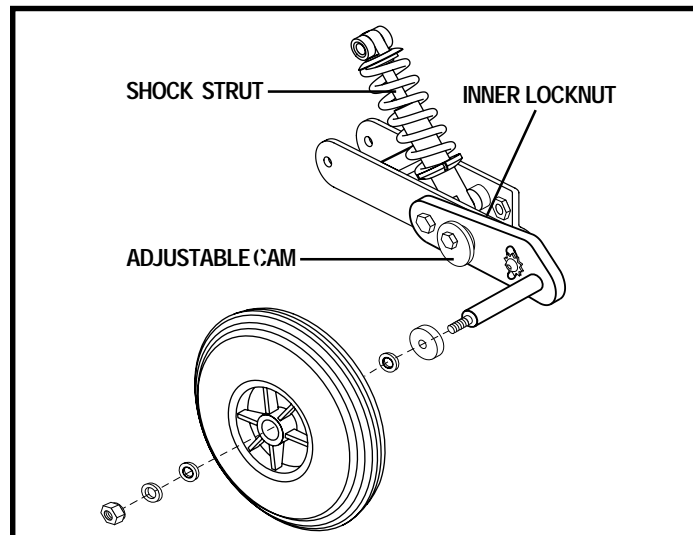

Figure 16. Anti-Tip Wheel Assembly

# VI. BATTERIES AND CHARGING

## BATTERIES AND CHARGING

The Quantum Jazzy 1650 uses two long-lasting, 12-volt, deep-cycle batteries. These batteries are sealed and maintenance free. Since they are sealed, there is no need to check the electrolyte (fluid) level. Deep-cycle batteries are designed to handle a longer and deeper discharge. Though they are similar in appearance to automotive batteries, they are not interchangeable. Automotive batteries are not designed to handle a long, deep discharge, and also are unsafe for use in power chairs.

WARNING! Battery posts, terminals, and related accessories contain lead and lead compounds. Wash hands after handling.



WARNING! Do not use batteries that exceed the recommended type and amp-hour capacity. Do not use batteries with different amp-hour capacities. Refer to the specifications table in this manual and in the manual supplied with the battery charger for recommended type and capacities.

## Charging the Batteries

The battery charger is essential in providing long life for your power chair's batteries. The battery charger is designed to optimize your power chair's performance by charging the batteries safely, quickly, and easily.



PROHIBITED! Removal of grounding prong can create electrical hazard. If necessary, properly install an approved 3-pronged adapter to an electrical outlet having 2-pronged plug access.



PROHIBITED! Never use an extension cord to plug in your battery charger. Plug the charger directly into a properly wired standard electrical outlet.

WARNING! You must recharge your power chair's batteries with the supplied charger. Do not use an automotive-type battery charger.

WARNING! Read the battery charging instructions in this manual and in the manual supplied with the battery charger before charging the batteries.

WARNING! Do not expose the battery charger to rain or other sources of moisture unless it has been tested for outdoor use. Refer to the manual supplied with the battery charger for more information.

WARNING! Explosive gases may be generated while charging the batteries. Keep the power chair and battery charger away from sources of ignition such as flames or sparks and provide adequate ventilation when charging the batteries.



WARNING! Inspect the battery charger, wiring, and connectors for damage before each use. Contact your authorized provider/specialist if damage is found.

WARNING! Do not attempt to open the battery charger case. If the battery charger does not appear to be working correctly, contact your authorized provider/specialist.

WARNING! If the battery charger is equipped with cooling slots, then do not attempt to insert objects through these slots.

WARNING! Do not allow unsupervised children to play near the power chair while the batteries are charging. Pride recommends that you do not charge the batteries while the power chair is occupied.

WARNING! If your battery charger has not been tested and approved for outdoor use, then do not expose it to adverse or extreme weather conditions. If the battery charger is exposed to adverse or extreme weather conditions, then it must be allowed to adjust to the difference in environmental conditions before use indoors. Refer to the manual supplied with the battery charger for more information.

# VI. BATTERIES AND CHARGING

## **To charge the batteries using the off-board charger:**

1. Position the front of your power chair next to a standard electrical outlet.
2. Be certain the controller power is turned off and the power chair is in drive mode.
3. Plug the off-board charger into the off-board charger/programming socket on the controller.
4. Plug the off-board charger into the electrical outlet.

***NOTE: If it is a Pride off-board charger, then there are two lights in it. The red light indicates that power to the off-board charger is on. The green light indicates that the batteries are fully charged. If it is not a Pride off-board charger, then follow the instructions supplied by the manufacturer.***

5. When the batteries are fully charged, unplug the off-board charger from the electrical outlet and then from the controller.

## **Battery Break-in**

### **To break in new batteries for maximum efficiency:**

1. Fully recharge any new battery prior to its initial use. This brings the battery up to about 90% of its peak performance level.
2. Operate your power chair throughout the house and yard. Move slowly at first, and do not stray too far until you become accustomed to the controls and break in the batteries.
3. Give the batteries another full charge of 8 to 14 hours and operate your power chair again. The batteries will now perform at over 90% of their potential.
4. After four or five charging cycles, the batteries will top off at 100% charge and last for an extended period.

## **Frequently Asked Questions (FAQs)**

### **How does the charger work?**

The battery charger takes the standard electrical outlet voltage of 120 VAC (alternating current) and converts it to 24 VDC (direct current). The power chair batteries use direct current to run your power chair. When the battery voltage is low, the charger works harder to charge the battery. As the battery voltage approaches full charge, the charger doesn't work as hard to complete the charging cycle. When the battery is fully charged, the amperage from the charger is nearly at zero. This is how the charger maintains a charge but does not overcharge the battery.

### **Can I use a different battery charger?**

You should use the charger supplied with the power chair. It is the safest, most efficient tool to charge the batteries. We do not recommend using other types of chargers (e.g., an automotive battery charger).

***NOTE: Your power chair's charger will not operate after the batteries have been discharged to nearly zero voltage. If this happens, call your authorized provider/specialist for assistance.***

### **How often must I charge the batteries?**

Many factors come into play when deciding how often to charge the batteries. You may use your power chair all day on a daily basis or you may not use it for weeks at a time.

#### **■ Daily Use**

If you use your power chair on a daily basis, charge the batteries as soon as you are finished using your power chair. Your power chair will be ready each morning to give you a full day's service. It is recommended that you charge the batteries 8 to 14 hours after daily use.

# VI. BATTERIES AND CHARGING

## ■ Infrequent Use

If you use your power chair infrequently (once a week or less), you should charge the batteries at least once per week for 12 to 14 hours.

**NOTE:** *Keep your batteries fully charged and avoid deeply discharging your batteries. Do not charge the batteries for more than 24 hours at a charging cycle.*

## How can I get maximum range or distance per charge?

Rarely do you have an ideal driving situation such as smooth, flat, hard terrain with no wind, hills, or curves. More often you are presented with hills, sidewalk cracks, uneven and loosely packed surfaces, curves, and wind. All of these factors will affect the distance or running time per battery charge. Below are a few suggestions for obtaining the maximum range per charge:

- Always charge the batteries fully prior to your trip.
- Plan your trip in advance to avoid inclines if possible.
- Limit baggage weight to essential items.
- Try to maintain an even speed and avoid stop-and-go driving.

## What type of batteries should I use?

We recommend deep-cycle batteries that are sealed and maintenance free. Both AGM and Gel-Cell are deep-cycle batteries that are similar in performance. Refer to the Specifications Table for more information regarding the batteries used with your power chair.



**WARNING!** Corrosive chemicals contained in battery. Use only AGM or Gel-Cell batteries to reduce the risk of leakage or explosive conditions.

## Why do my new batteries seem weak?

Deep-cycle batteries employ a much different chemical technology than that used in car batteries, nickel-cadmium (nicads), or in other common battery types. Deep-cycle batteries are specifically designed to provide power, drain down their charge, and then accept a relatively quick recharge. AGM and Gel-Cell batteries should be charged as often as possible. They do not have a “memory” like nickel-cadmium batteries.

We work closely with our battery manufacturer to provide a battery that best suits your power chair’s specific demands. Fresh batteries arrive regularly at Pride and are promptly shipped with a full charge. During shipping, the batteries encounter temperature extremes that may influence initial performance. Heat robs the charge from the battery, and cold slows the power available and extends the time needed to recharge the battery (just as with a car battery).

It might take a few days for the temperature of the battery to stabilize and adjust to its new ambient temperature. More importantly, it will take a few “charging cycles” (a partial drain-then a full recharge) to establish the critical chemical balance that is essential to the battery’s peak performance and long life. It will be well worth it to take the time to break in your battery properly.

**NOTE:** *The useful life of a battery is quite often a reflection of the care it receives.*

## VI. BATTERIES AND CHARGING

### **How can I ensure maximum battery life?**

A fully charged deep-cycle battery will provide reliable performance and extended battery life. Keep your power chair's batteries fully charged whenever possible. Batteries that are regularly and deeply discharged, infrequently charged, or stored without a full charge may be permanently damaged, causing unreliable power chair operation and limited battery life.

### **How should I store my power chair and its batteries?**

If you do not use your power chair regularly, we recommend maintaining battery vitality by charging the batteries at least once per week. If you do not plan on using your power chair for an extended period, fully charge the batteries prior to storage. Disconnect the battery harnesses and store the power chair in a warm, dry environment. Avoid temperature extremes, such as freezing and excessively hot conditions, and never attempt to charge a frozen battery. A cold or frozen battery should be warmed for several days prior to recharging.

### **What about public transportation?**

AGM and Gel-Cell batteries are designed for application in power chairs and other mobility vehicles. These batteries are Federal Aviation Administration (FAA) approved, allowing safe transportation on aircraft, buses, and trains, as there is no danger of spillage or leakage. We suggest you contact the carrier's ticket counter in advance to determine that carrier's specific requirements.

### **What about shipping?**

If you wish to use a freight company to ship your power chair to your final destination, repack your power chair in the original shipping container and ship the batteries in separate boxes.

# VII. CARE AND MAINTENANCE

## CARE AND MAINTENANCE

Your Quantum Jazzy 1650 is a sophisticated power chair. Like any motorized vehicle, it requires routine maintenance checks. You can perform some of these checks, but others require assistance from your authorized provider/specialist. Preventive maintenance is very important. If you follow the maintenance checks in this section as scheduled, you can help ensure that your power chair gives you years of trouble-free operation. If you have any doubt as to your power chair's care or operation, contact your authorized provider/specialist.



**WARNING!** Do not service the power chair when the seat is occupied.

Your power chair, like most electrical equipment, is susceptible to damage from the elements. Avoid damp areas of any kind.



**WARNING!** Direct or prolonged exposure to water or dampness could cause the power chair to malfunction electronically and mechanically. Water can cause electrical components to corrode and the chair's frame to rust. Power chairs should be examined periodically for signs of corrosion caused by water exposure, bodily fluid exposure, or incontinence. Damaged components should be replaced or treated immediately.

### Should your power chair come in contact with water:

1. Dry your power chair as thoroughly as possible with a towel.
2. Allow your power chair to sit in a warm, dry place for 12 hours to allow unseen water to evaporate.
3. Check the joystick operation and the brakes before using your power chair again.
4. If any inconsistencies are found, take your power chair to your authorized provider/specialist. Power chairs that are frequently exposed to sources of water, such as incontinence, should be inspected often for corrosion and electronic components may need to be replaced frequently.

### Temperature

- Some of the parts of your power chair are susceptible to extreme changes in temperature. Always keep your power chair between the temperatures of 18°F (-8°C) and 122°F (50°C).
- In extremely cold temperatures the batteries may freeze. The specific temperature at which they freeze depends on a number of factors, such as battery charge, usage, and composition of the batteries (e.g., AGM or Gel-Cell).
- Temperatures above 122°F (50°C) may cause your power chair to operate at a reduced speed. This reduced speed is a safety feature built into the controller that helps prevent damage to the motor and other electrical components.

### General Guidelines

- Avoid knocking or bumping the controller, especially the joystick.
- Avoid prolonged exposure of your power chair to extreme conditions, such as heat, cold, or moisture.
- Keep the controller clean.
- Check all connectors to ensure that they are all tight and secured properly.
- Make sure the drive tires are inflated to **35 psi (2.4 bar)** if equipped with pneumatic tires.



**WARNING!** Make sure your tires are inflated to 35 psi (2.4 bar). Do not underinflate or overinflate your tires. Low pressure may result in loss of control, and overinflated tires may burst. Overinflating tires can cause them to explode.

**WARNING!** Do not use a high pressure hose to inflate your tires.

- Use a rubber conditioner on the tire sidewalls to help preserve them.



**WARNING!** Never use a rubber conditioner on the tread area of the tires; doing so may make the tires slippery and cause your power chair to skid.



# VII. CARE AND MAINTENANCE

- All wheel bearings are prelubricated and sealed. They require no subsequent lubrication.
- The body shroud has been sprayed with a clear sealant coating. You can apply a light coat of car wax to help it retain its high-gloss appearance.
- Check all electrical connections. Make sure they are tight and are not corroded. Batteries must sit flat within the battery tray, with the battery terminals facing inward, toward each other. Refer to the battery wiring label for the correct wiring layout.



WARNING! Even though the power chair has passed the necessary testing requirements for ingress of liquids, you should keep electrical connections away from sources of dampness, including direct exposure to water or bodily fluids and incontinence. Check electrical components frequently for signs of corrosion and replace as necessary.

## Daily Checks

- With the controller turned off, check the joystick. Make sure it is not bent or damaged and that it returns to the neutral position when you release it. Check the rubber boot around the base of the joystick for damage. Visually inspect the boot. Do not handle or try to repair it. See your authorized provider/specialist if there is a problem.
- Visually inspect the controller communications cable. Make sure that it is not frayed, cut, or has any wires exposed. See your authorized provider/specialist if there is a problem.
- Check for flat spots on solid tires. Flat spots could adversely affect stability.

## Weekly Checks

- Disconnect and inspect the controller from the power base. Look for corrosion. Contact your authorized provider/specialist if necessary.
- Ensure that all parts of the controller system are securely fastened to your power chair. Do not overtighten any screws.
- Check for proper tire inflation. There should be **35 psi (2.4 bar)** in each tire. If a tire does not hold air, see your authorized provider/specialist for replacement of the tube.
- Calibrate the joystick if a noticeable difference in performance is detected or if the joystick does not operate properly. To calibrate the joystick, power off the unit, place the joystick in the neutral position, and power the unit back on. If a problem still exists with your joystick's performance, contact your authorized provider/specialist.
- Check the brakes. This test should be carried out on a level surface with at least three feet of clearance around your power chair.

### To check the brakes:

1. Turn on the controller and turn down the speed level of your power chair.
2. After one second, check the battery condition meter. Make sure that it remains on.
3. Slowly push the joystick forward until you hear the electric brakes click. Immediately release the joystick. You must be able to hear each electrical brake operating within a few seconds of joystick movement. Repeat this test three times, pushing the joystick backwards, then left, and then right.

## Monthly Checks

- Check that the anti-tip wheels do not rub the ground when you operate the power chair. Adjust them as necessary. See V. "Comfort Adjustments."
- Check for extreme wear on the anti-tip wheels. Replace them as necessary.
- Check for drive tire wear. See your authorized provider/specialist for repair.
- Check the caster wheels for wear. Replace them as necessary.
- Check the caster forks for damage or fluttering which indicates that they may need to be adjusted or have the bearings replaced. See your authorized provider/specialist for repair.
- Keep your power chair clean and free of foreign material, such as mud, dirt, hair, food, drink, etc.

# VII. CARE AND MAINTENANCE

## Yearly Checks

Take your power chair to your authorized provider/specialist for yearly maintenance, especially if you use your power chair on a daily basis. This helps ensure that your power chair is functioning properly and helps prevent future complications.

## Storage

Your power chair should be stored in a dry place, free from temperature extremes. When storing, disconnect the batteries from the power chair. See VI. “Batteries and Charging.”



**WARNING!** If you fail to store the unit properly, the frame can rust and the electronics can be damaged.

Batteries that are regularly and deeply discharged, infrequently charged, stored in extreme temperatures, or stored without a full charge may be permanently damaged, causing unreliable performance and limited service life. It is recommended that you charge the batteries periodically throughout periods of prolonged storage to ensure proper performance.

You may wish to place several boards under the frame of your power chair to raise it off of the ground during periods of prolonged storage. This takes the weight off of the tires and reduces the possibility of flat spots developing on the areas of the tires contacting the ground.

## Disposal of Your Power Chair

Your power chair must be disposed of according to applicable local and national statutory regulations. Contact your local waste disposal agency or authorized provider/specialist for information on proper disposal of power chair packaging, metal frame components, plastic components, electronics, and batteries.

## Cleaning and Disinfection

- Use a damp cloth and mild, non-abrasive cleanser to clean the plastic and metal parts of your power chair. Avoid using products that may scratch the surface of your power chair.
- If necessary, clean your product with an approved disinfectant. Make sure the disinfectant is safe for use on your product before application.

**WARNING!** Follow all safety instructions for the proper use of the disinfectant and/or cleaning agent before applying it to your product. Failure to comply may result in skin irritation or premature deterioration of upholstery and/or power chair finishes.



**WARNING!** Never hose off your power chair or place it in direct contact with water. Your power chair has a painted, ABS plastic body shroud that allows it to be easily wiped clean with a damp cloth.

**WARNING!** Never use any chemicals to clean a vinyl seat, as they may cause the seat to become slippery or dry out and crack. Use soapy water and dry the seat thoroughly.

## Wheel Replacement

If you have pneumatic tires and you have a flat tire, you can replace the tube. If your chair is equipped with a solid tire insert, then you must replace the whole wheel assembly. Replacement tires, tubes, and wheel assemblies are readily available through your authorized provider/specialist.



**WARNING!** Be sure that the controller's power is turned off and the power chair is not in freewheel mode before performing this procedure.

**WARNING!** When changing a tire, remove only the center lug nut and washer, then remove the tire. If any further disassembly is required, deflate the tire completely or it may explode.

## VII. CARE AND MAINTENANCE

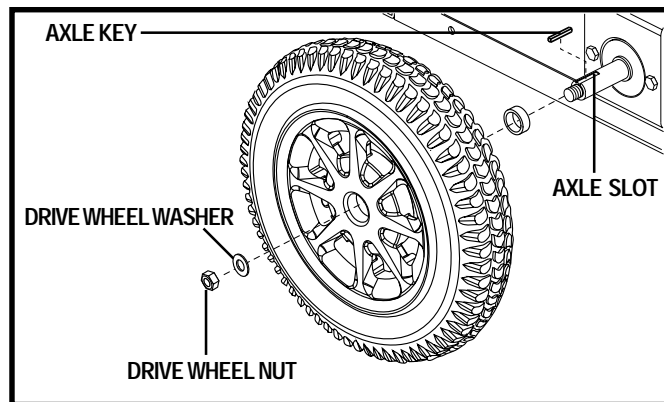

Figure 17. Quantum Jazzy 1650 Drive Wheel

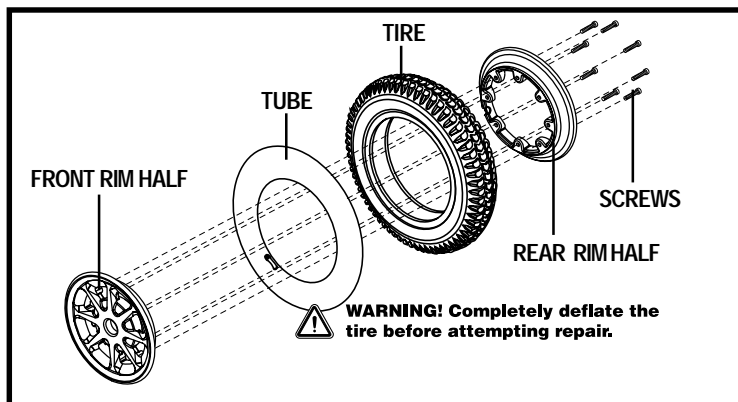

Figure 18. Quantum Jazzy 1650 Drive Wheel Disassembled

### Follow these easy steps for a quick and safe repair for both pneumatic and solid tires:

1. Turn off the power to the controller.
2. Set the power chair up on blocks.
3. If you are changing a pneumatic tire, completely deflate it before removing the wheel.
4. Remove the drive wheel nut and washer from the axle. See figure 17.
5. Pull the wheel off the axle.
6. Remove the screws from the rim assembly and separate the front and rear rim. See figure 18.
7. Remove the old tube from the pneumatic tire and replace it with a new tube or replace the entire assembly if it is a solid tire.
8. Reassemble the rims and reinstall the screws.
9. Slide the wheel back onto the axle. Make sure the key is in the axle slot.
10. Reinstall the drive wheel nut and washer onto the wheel axle and tighten.
11. Inflate the pneumatic tire to **35 psi (2.4 bar)**.
12. Remove the power chair from the blocks.

### Battery Replacement

A battery wiring diagram is printed on a decal located on the battery tray. See VI. "Batteries and Charging" for correct battery specifications.

WARNING! Do not replace the batteries when the seat is occupied.

WARNING! Battery posts, terminals, and related accessories contain lead and lead compounds. Wear goggles and gloves when handling batteries and wash hands after handling.



WARNING! Power chair batteries are heavy. See specifications table. If you are unable to lift that much weight, be sure to get help. Use proper lifting techniques and avoid lifting beyond your capacity.

WARNING! Do not mix or match new and old batteries. If you encounter a situation where one battery needs to be replaced, then replace both batteries. Refer to the specifications table in this manual and the manual supplied with the battery charger for recommended type and capacities.

# VII. CARE AND MAINTENANCE

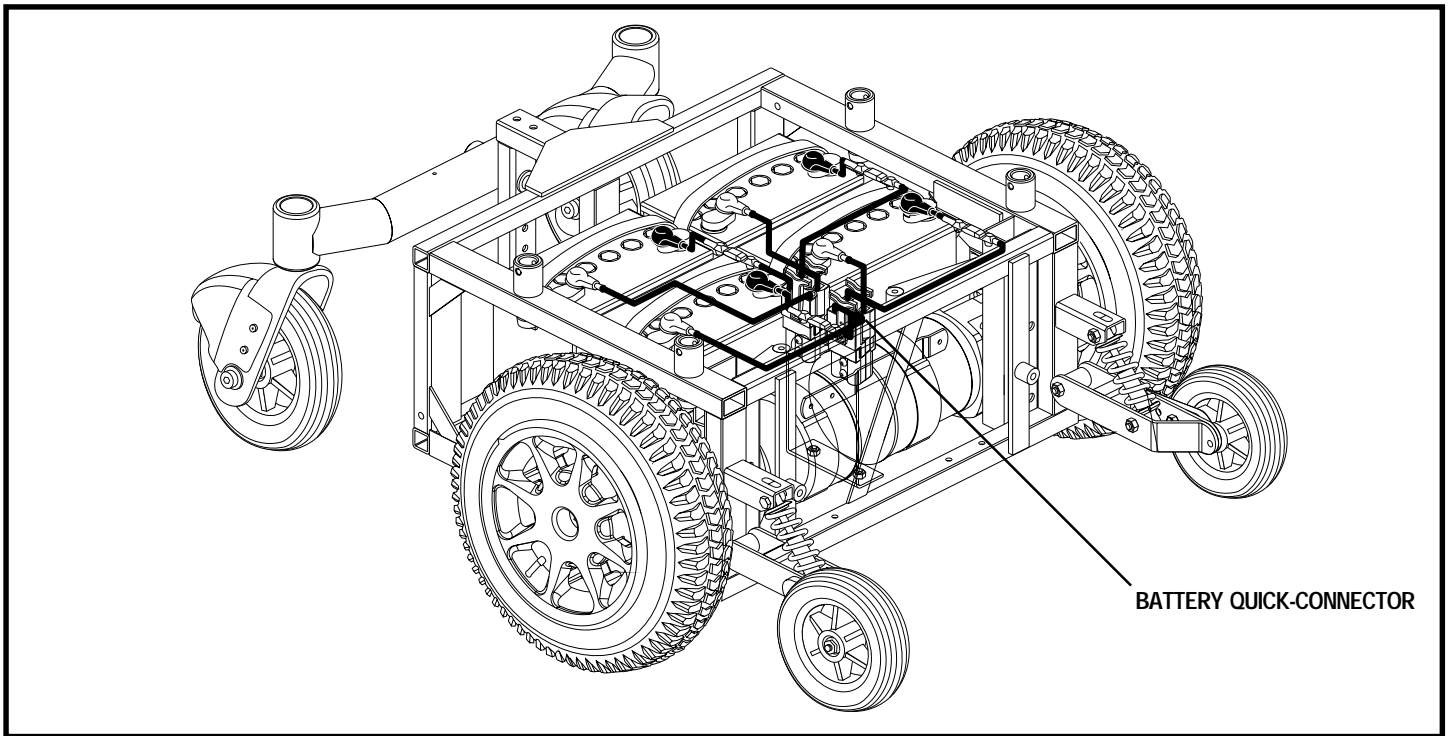

Figure 19. Quantum Jazzy 1650 Battery Connections (4-Battery Configuration)

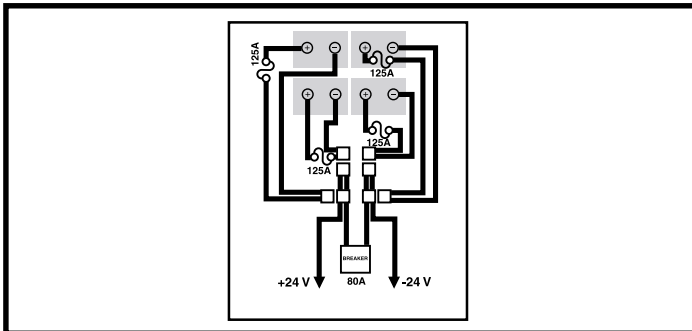

Figure 20. Battery Wiring Diagram (4 Batteries)

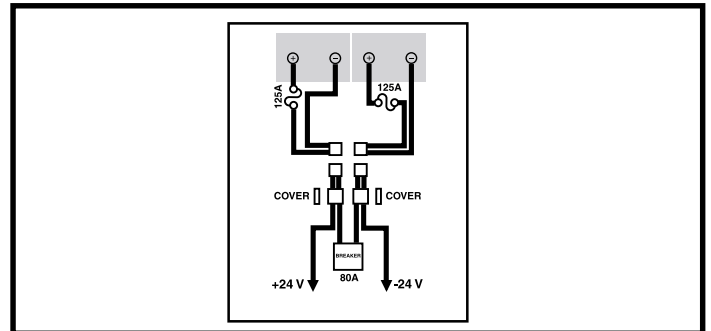

Figure 21. Battery Wiring Diagram (2 Batteries)

## To replace the batteries:

1. Turn off the power to the controller.
2. Make sure that the power chair is in drive mode. See III. “Your Power Chair.”
3. Unplug the controller communications cable from the power base.
4. Remove the seat.
5. Lift off the shroud
6. Unplug the battery quick-connector from the powerbase. See figure 19.
7. Remove the old batteries.
8. Disconnect the wiring harnesses from the batteries. See figures 20 and 21.
9. Connect the wiring harness to the new batteries.



WARNING! Make sure you tighten the fasteners so that the connections are secure.

## VII. CARE AND MAINTENANCE

10. Place the batteries back onto the power base.
11. Plug in the quick-disconnects.
12. Reinstall the shroud.
13. Reinstall the seat.
14. Reinstall the controller communications cable.
15. Charge the batteries.

### **When to See Your Authorized Provider/Specialist for Service**

The following symptoms could indicate a serious problem with your power chair. If necessary, contact your authorized provider/specialist. When calling, have the model number, serial number, nature of the problem, and the trouble code if available.

- Motor noise
- Frayed harnesses
- Cracked or broken connectors
- Uneven wear on any of the tires
- Jerky motion
- Pulling to one side
- Bent or broken wheel assemblies
- Does not power up
- Powers up, but does not move

### **Corrective Maintenance**

If the battery condition meter does not light up when you turn on the power:

- Check the harness connections. Make sure they are tight.
- Check the circuit breaker. Reset it if necessary.
- Check the battery connections.

If the above conditions prove normal, you can load test the batteries with a battery load tester. These testers are available at automotive parts stores. Disconnect both batteries before load testing and follow the directions that come with the load tester. If either one of the batteries fails the load test, replace both of them. If your power chair still does not power up, contact your authorized provider/specialist.

# V I I I . W A R R A N T Y

## LIFETIME LIMITED WARRANTY

For the lifetime of your power chair from the date of purchase, Pride will repair or replace at our option to the original purchaser, free of charge, any of the following parts found upon examination by an authorized representative of Pride to be defective in material and/or workmanship:

### **Structural frame components, including:**

- Main Frame
- Fixed-position seat post

## TWO-YEAR LIMITED WARRANTY

For two (2) years from the date of purchase, Pride will repair or replace at our option to the original purchaser, free of charge, any of the following parts found upon examination by an authorized representative of Pride to be defective in material and/or workmanship:

### **Electronic components, including:**

- Charger Assembly
- Controller
- Joystick

### **Main frame assemblies, including:**

- Anti-tip forks
- Caster forks
- Caster beam
- Metal seat framing

### **Other components, including:**

- Foot riggings
- Electrical Harness
- Foot rigging mounting brackets

## 18-MONTH LIMITED WARRANTY

For eighteen (18) months from the date of purchase, Pride will repair or replace at our option to the original purchaser, free of charge, any of the following parts found upon examination by an authorized representative of Pride to be defective in material and/or workmanship:

- Motor/gearbox assembly
- Power seat actuator

## ONE-YEAR LIMITED WARRANTY

For one (1) year from the date of purchase, Pride will repair or replace at our option to the original purchaser, free of charge, any of the following parts found upon examination by an authorized representative of Pride to be defective in material and/or workmanship:

- Accessories
- Brakes (electronic function ONLY)

## SIX-MONTH LIMITED WARRANTY

For six (6) months from the date of purchase, Pride will repair or replace at our option to the original purchaser, free of charge, any of the following parts found upon examination by an authorized representative of Pride to be defective in material and/or workmanship:

- Bearings and bushings
- Plastic components, except body

The battery is covered by a separate six-month warranty, provided by the battery manufacturer. The batteries are not warranted by Pride.

# V I I I . W A R R A N T Y

## RECONDITIONED UNITS WARRANTY

All reconditioned units are covered by a six-month warranty from Pride effective from the date of purchase.

## WARRANTY EXCLUSIONS

This warranty does not extend to those items which may require replacement due to normal wear and tear.

- ABS Plastic shrouds
  - Motor brushes
  - Upholstery and seating
  - Brake Pads
  - Tires and tubes
  - Fuses/Bulbs
- Circumstances beyond the control of Pride
  - Labor, service calls, shipping, and other charges incurred for repair of the product, unless specifically authorized, IN ADVANCE, by Pride Mobility Products Corporation
  - Repairs and/or modifications made to any part without specific consent from Pride

### **Exclusions also include components with damage caused by:**

- Contamination
- Abuse, misuse, accident, or negligence
- Battery fluid spillage or leakage
- Commercial use, or use other than normal
- Improper operation, maintenance, or storage

***NOTE: Gradual deterioration in performance because the battery has been left in a discharged state, left in cold conditions for an extended period of time, or worn out through heavy use is not covered.***

## SERVICE CHECKS AND WARRANTY SERVICE

Warranty service must be performed by an authorized provider/specialist. Do not return faulty parts to Pride without prior written authorization. All transportation costs and shipping damage incurred while submitting parts for repair or replacement are the responsibility of the purchaser.

Failure to follow the instructions, warnings, and notes in the owner's manual and those located on your Pride product can result in personal injury or product damage and will void Pride's product warranty.

There is no other express warranty.

## IMPLIED WARRANTIES

Implied warranties, including those of merchantability and fitness for a particular purpose, are limited to one (1) year from the date of purchase and to the extent permitted by law. Any and all implied warranties are excluded. This is the exclusive remedy. Liabilities for consequential damages under any and all warranties are excluded.

Some states do not allow limitations on how long an implied warranty lasts or do not allow the exclusion of limitation incidental or consequential damages. The above limitation or exclusion may not apply to you.

This warranty gives you specific rights, and you may also have other rights which vary from state to state.

Please fill out and return the product registration card to Pride. This will aid Pride in providing the best possible technical and customer service.

# NOTES



# NOTES

# NOTES



## Quality Control - Quantum Jazzy 1650 Series

Inclusion of all Parts

\_\_\_\_\_  
Joystick Serial Number

\_\_\_\_\_  
Controller Serial Number

\_\_\_\_\_  
Left Motor Serial Number

\_\_\_\_\_  
Right Motor Serial Number

Fit and Finish

Performance



**Pride keeps a more detailed report on file at the factory.**

\_\_\_\_\_  
**Date Inspected**

\_\_\_\_\_  
**Inspector**

\* I N F M A N U 2 3 9 5 \*

\_\_\_\_\_  
**Product Serial #**